



KT12

CNC Sink Center

The new KT12 Sink CNC from AitalMac will provide ease and accurate sink cutouts with speed, as well as offer as additional CNC cutting station for facilities with limited space for a full-size CNC machine.

The KT12 includes two loading tables, which will reduce waiting time between finishing one cut and loading the next piece. While the open design makes it easy to load and unload each countertop, another benefit of this machine is its speedy process and alignment blocks that immediately set with pneumatic locking pistons.

The user-friendly interface also allows users to choose between your loaded sink cutouts DXF, quickly find the center through laser pointing, and begin cutting with efficiency and precision.

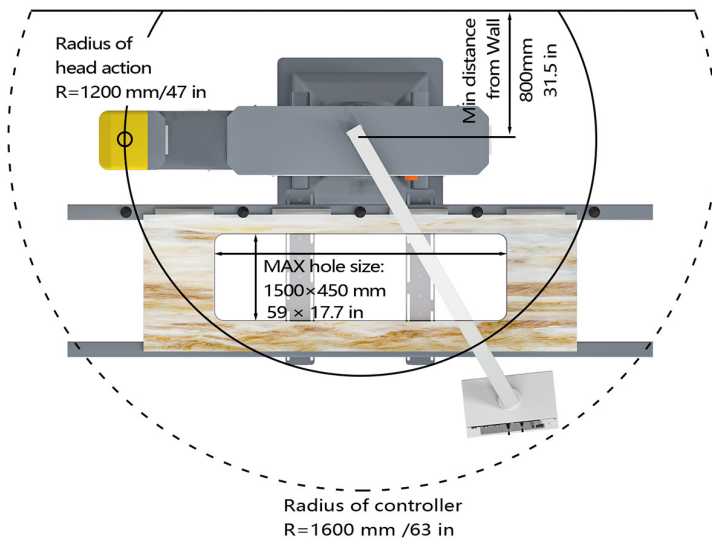
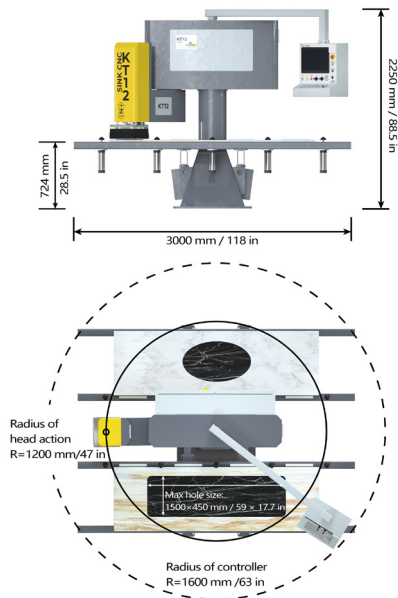

KT12

CNC Sink Center

The new KT12 Sink CNC from AitalMac will provide ease and accurate sink cutouts with speed, as well as offer as additional CNC cutting station for facilities with limited space for a full-size CNC machine.

TECHNICAL DATA

Max. tool diameter	50 mm
Electric spindle power	11 kw
Variable cutting & return speed	0-30 m/min
Air pressure	6 bar
Total weight	1500 kg
Water consumption	20-50 l/min
Max. install power	11/220V single phase
Power requirements	12 kw / 220 v / 2phase